

3D-Ansicht
1:1

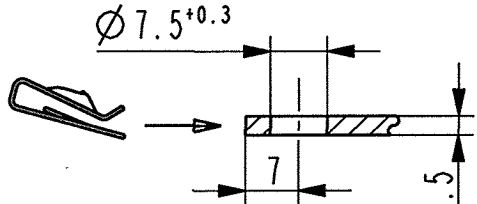

Einbausituation
1:1

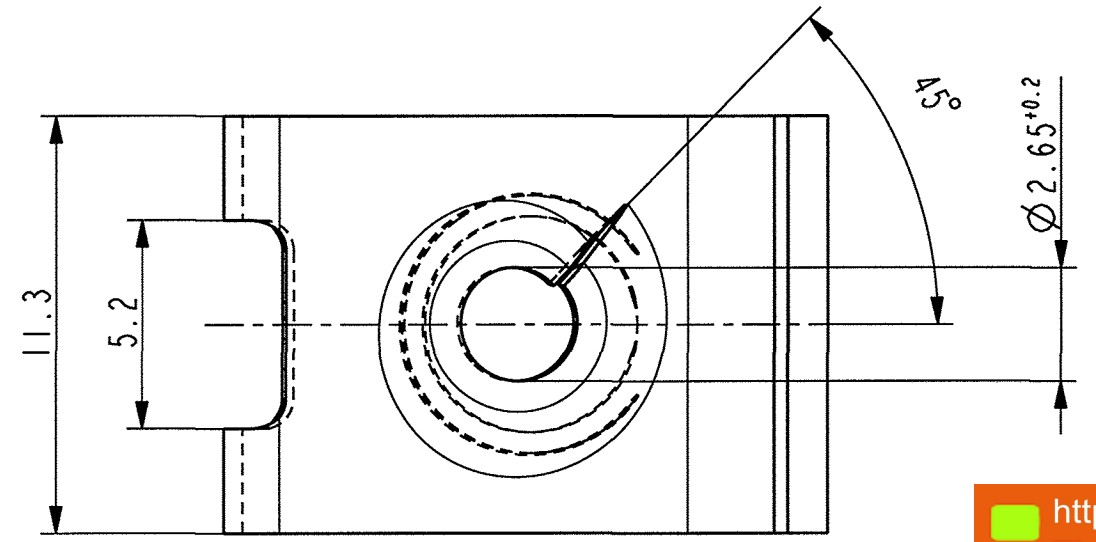
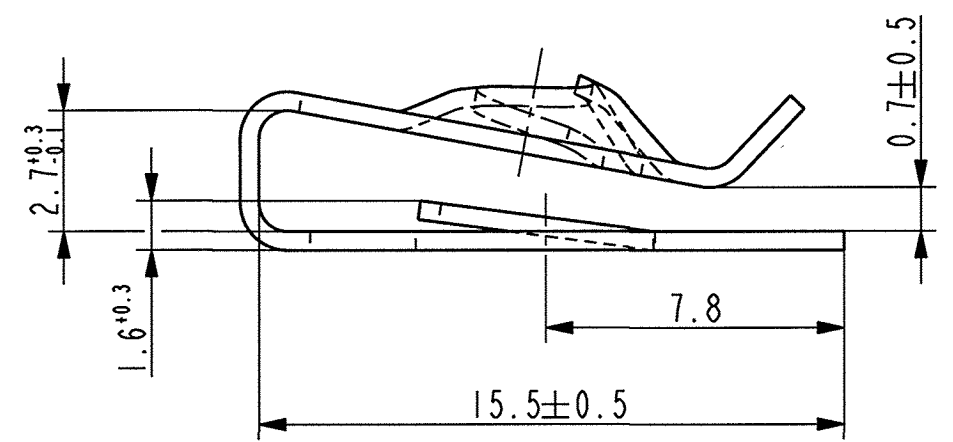

<http://www.cergy-vis.fr>
[CERGY-VIS]
 ET SI ON PARLAIT SERVICE

Vor Auslegung einer automatisierten Verarbeitung des Teils sollte Rücksprache mit Fa. A.Raymond gehalten werden.
 Fully automatic processing of the part requires prior consultation with A.Raymond GmbH.

-	-	-	-	-
-	-	-	-	-
-	-	-	-	-
-	-	-	-	-
-	-	-	-	-
-	-	-	-	-
-	-	-	-	-
-	-	-	-	-
-	-	-	-	-
-	-	-	-	-
-	-	-	-	-
-	-	-	-	-
-	-	-	-	-
-	-	-	-	-
Ab	-	Teildarstellung ohne Oberflächenbehandlung entfernt	23.09.08	Ru
Aa	lx	Indexreform, Art.-Nr. gem. SAP geänd.,	14.11.07	Ru
-	-	Schichtdicke 120-200 µm war 150±50µm	-	-
Ind.	Kompl vorr / Box offen	Beschreibung / Description	Datum/Date	Name

Aenderungen / Modifications

Format DIN A3
 A RAYMOND
A Raymond
 GmbH & Co. KG
 SPEZIALBEFESTIGUNGSSYSTEME WELTWEIT / ENGINEERED FASTENERS WORLDWIDE

Bei Verstaendnisproblemen beantragen Sie bitte beim Absender die deutsche Fassung vor jeder Anwendung.
 "CONDITIONS OF USE"
 This drawing and all information (the "Drawing") disclosed are the exclusive property of A.Raymond. By using this Drawing the Addressee acknowledge and accept that this Drawing (1) is covered by A.Raymond' intellectual property rights or know-how and (2) is provided under the following conditions who represent a Deposit Agreement. This Drawing is for Addressee' internal use only limited to its estimation. Without prior written consent of A.Raymond, no permission or rights for any purpose, is hereby granted, such as, without any limitation, (1) the copy, in part or entirely (2) and/or the presentation, in part or entirely, to any other third party outside the Addressee' company or in the company but with no interest (3) and/or the distribution of the Drawing, in part or entirely, in any medium (4) and/or the creation of any derivative work. In case of breach of these conditions, Addressee shall indemnify A.Raymond from and against all damages (compensatory or consequential), costs, expenses and charges, caused or arising out of or attributable to its willful misconduct, fraud, negligence, infringement of A.Raymond' intellectual property rights. If the Addressee does not accept these conditions, please notify A.Raymond' sender immediately.

Dateiname/ Filename	CAD-PE: 014637_C.01			-	
Ersatz fuer/ Substitute for	Art. 14637 Ae. Ind. I v. 21.01.98	Proj.-Nr./ Proj.-No.	59937	RASCH- Code	AABAC
		Vol.(mm ³)	-	Gewicht/ Weight (g)	-

Schutzrechte/
Patent rights vorbehalten / all rights reserved

Gepr./ App.	F.-gepr./ Produktion	Q.-gepr./ Quality	S.-gepr./ Patent app.	
Masstab / scale	Allgem.Tol. wenn nicht anders angegeben/ General tol. unless otherwise specified		Datum/ Date	14.11.2007
5:1	±0.25 / ±5°		Gez./ Drawn	Ruzicka

Oberflächenbehandlg./
Finish PA11-beschichtet, unglatt, (Aa) schwarz Schichtdicke 120 - 200 µm
 Kennzahl/
Code number 7400

Werkstoff(behandlg.)/
Material treatment zwischenstufenverguetet 435 ... 535 HV 5
 Blechdicke/
Mat.Thickn. DIN EN 10 140 0.5

Werkstoff/
Material C 67 S DIN EN 10 132-4
 Mat.-Code 1000

Benennung/
Partname Blechmutter fuer Gewinde EN ISO 1478 - ST-3.9

Teil-Nr. / Part-No.	014637 001	C
------------------------	------------	---

-	-	-
Teil-Nr. / Part-No.	Oberfläche / Farbe / Finish / colour	Kennzahl/ Code
	Ausfuehrung / Execution	