

Isometrische Ansicht /
isometric view
2:1

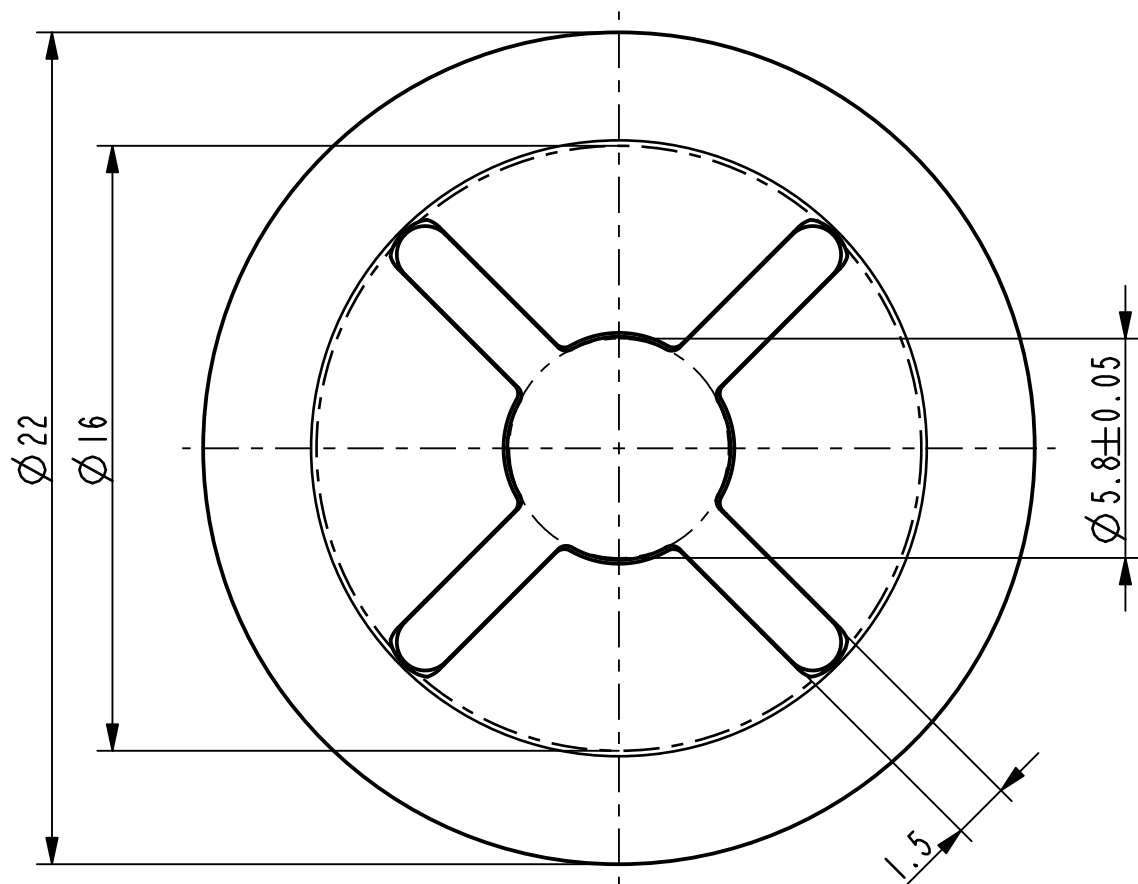

-	-	-
Teil-Nr. / part no.	Oberflaeche / Farbe / finish / colour	Oberfl. Code/ finish code
Ausfuehrung / Execution		

Vor Auslegung einer automatisierten Verarbeitung des Teils sollte Ruecksprache mit Fa. ARaymond gehalten werden.
Fully automatic processing of the part requires prior consultation with ARaymond.

-	-	-	-	-
-	-	-	-	-
-	-	-	-	-
-	-	-	-	-
-	-	-	-	-
-	-	-	-	-
-	-	-	-	-
-	-	-	-	-
-	-	-	-	-
-	-	-	-	-

Ba	-	Oberflaechevariante entfernt (3000, 3100, 3150)	29.06.11	mj
Rev.	Anzahl/ quantity	Aenderungsbeschreibung / modification description	Datum/date	Name



Teichstrasse 57
Germany - 79511 Loerrach
Phone +49 (0) 7621 174-0
Fax +49 (0) 7621 174-225

Bei Verstaendnisproblemen beantragen Sie bitte beim Absender die deutsche Fassung vor jeder Anwendung.
"CONDITIONS OF USE"
This drawing and all information (the "Drawing") disclosed are the exclusive property of ARaymond. By using this Drawing the Addressee acknowledges and accepts that this Drawing (1) is covered by ARaymond' intellectual property rights or know-how and (2) is provided under the following conditions who represent a Deposit Agreement. This Drawing is for Addressee' internal use only limited to its estimation. Without prior written consent of ARaymond, no permission or rights for any purpose, is hereby granted, such as, without any limitation, (1) the copy, in part or entirely, (2) and/or the presentation, in part or entirely, to any other third party outside the Addressee' company or in the company but with no interest (3) and/or the distribution of the Drawing, in part or entirely, in any medium (4) and/or the creation of any derivative work. In case of breach of these conditions, Addressee shall indemnify ARaymond from and against all damages (compensatory or consequential), costs, expenses and charges, caused or arising out of or attributable to its willful misconduct, fraud, negligence, infringement of ARaymond' intellectual property rights. If the Addressee does not accept these conditions, please notify ARaymond' sender immediately.

Intellectual property rights	vorbehalten / all rights reserved		Classification code	EAAA-
Ersatz fuer/ substitut for	019236_c_01/B/28.09.2005	Entw.Ref./ dev.ref.	Projekt-Nr./ project no.	

Masstab/ scale	Format	Allgemeintoleranz/ general tolerance	Datum/ date	29.06.2011
5:1	A3	±0.3	Erstellt von/ prepared by	M. Junge

Projektion / projection	ALL DIMENSIONS ARE IN MILLIMETERS	Freigegeben/ approved	20110629085611	
	Blechedicke/ mat. thickness DIN EN 10140	0.45	Volumen/ volume (mm³)	152.5
			Gewicht/ weight (g)	1.2

Oberfl. / finish	verzinkt / passiviert farblos zinc plated / passivated colourless	Oberfl. Code/ finish code	3250
---------------------	--	------------------------------	------

Werkstoffbehandl./ material treatment	zwischenstufenverguetet / austempered 435 ... 535 HV 5
--	---

Werkstoff/ material	C67S DIN EN 10132-4	Mat. code	1000
------------------------	---------------------	-----------	------

Benennung/
title
Federmutter
 fuer Bolzen Ø6+0.1
spring nut
 for bolt Ø6+0.1

Teil-Nr. / part no.	019236-0-04	Drawing type	C:Customer
------------------------	-------------	--------------	------------

Kundenteile-Nr. / customer part no.	-	Blatt / sheet	1 / 1
CAD system & version	ProE WF4	Dateiname / filename	019236-0C00